

MORSE MODULARI DI PRECISIONE SERIE "STANDARD"

PRECISION MODULAR VISES "STANDARD" SERIES

ETAUX MODULAIRES DE PRECISION SERIE "STANDARD"

HOCHPRÄZISE MODULARSCHRAUBSTÖCKE SERIE "STANDARD"

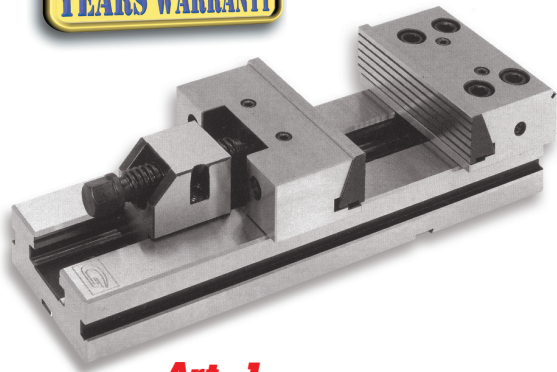

Art. 1

Morsa con ganascia mobile guidata
 Vise with guided movable jaw
 Etau avec morsa mobile guidé
 Schraubstock mit beweglichem Backen

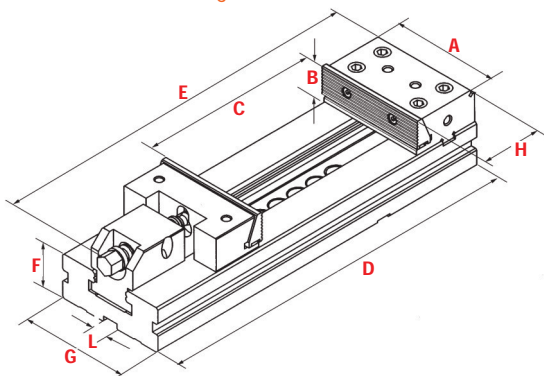

DOTAZIONE STANDARD

Ciascuna morsa completa viene fornita con la seguente dotazione:
 1 arresto laterale Art. 370
 1 coppia di tasselli di posizionamento Art. 297 (standard per cava da 16mm)
 1 chiave a pipa Art. 375 - 1 chiave a "T" Art. 376
OPTIONAL: FORI CALIBRATI SU RICHIESTA



STANDARD EQUIPMENT

Each complete vise is supplied with the following standard accessories:
 1 workstop Art. 370
 1 pair of positioning key-nuts Art. 297 (standard for 16mm slot)
 1 box-wrench Art. 375 - 1 wrench a "T" Art. 376
OPTION: GROUND HOLES ON REQUEST



EQUIPEMENT STANDARD

Chaque étau est fournie avec les articles suivants:
 1 butée latérale Art. 370
 1 jeu de tasseaux de positionnement Art. 297 (pour rainures de 16 en standard)
 1 clé coudée Art. 375 - 1 clé en T Art. 376
OPTIONS: TROUS CALIBRES SUR DEMANDE



STANDARD AUSSTATTUNG

Jeder Schraubstock wird mit der folgenden Standardausstattung geliefert:
 1 Werkstückanschlag Art. 370
 1 Paar Nutensteine Art. 297 (für T-Nutenbreite 16mm)
 1 Spannschlüssel Art. 375
 1 Inbusschlüssel Art. 376
OPTIONAL: KALIBRIERTE BOHRUNGEN AUF ANFRAGE

Altissima precisione
 Possibilità di allineamento di più morse
 Ganasce discendenti
 Durata illimitata
 Costruzione solida e compatta
 Usura praticamente inesistente
 Capacità di bloccaggi illimitati
 Acciaio temprato e rettificato HRC60

High precision and gang operation
 Pull down easy to change jaws
 Unlimited longevity
 Space saving design
 No "wear" construction
 Unlimited clamping range
 All steel construction
 hardened and ground HRC60

Haute précision
 Possibilité d'alignement des mors
 Mors auto plaqueurs à changement simple
 Grande longévité
 Conception compacte
 Usure quasi inexistante
 Possibilité de serrages illimité
 En acier trempé 60HRC

Hohe Präzision
 Einfache Handhabung
 Einfachwechselbare Spannbacken
 Langlebig
 Geringe Aufbauhöhe
 Vielseitige Spannmöglichkeiten
 Hohe Verschleißfestigkeit
 Aus gehärtetem und geschliffenem Stahl HRC60

mm	TIPO MORSA								VISE SIZE				TYPE D'ETAU				SCHRAUBSTOCKTYP			
	1	2	3	4				5				6								
A	100	125	150	175				200				300								
B	30	40	50	60				65				80								
C	100	150	200	300	200	300	400	500	200	300	400	500	600	200	300	400	500	600	700	800
D	270	345	420	520	455	555	655	755	495	595	695	795	895	535	635	735	835	935	1035	1135
E	320	410	500	600	530	630	730	830	580	680	780	880	980	630	730	830	930	1030	1130	1230
F	35	40	50	58				70				78								
G	75	95	125	145				170				195								
H	77.9	77.9	89.4	96.9				113.4				120.4								
L	16	16	16	16				16				16								
kg	6.8	12.9	25.5	29	37	42	47	52	64	69	74	79	84	95	105	115	125	135	145	155

inch	TIPO MORSA				VISE SIZE				TYPE D'ETAU				SCHRAUBSTOCKTYP							
	4"	5"	6"	7"				8"				12"								
A	3.9	4.9	5.9	6.8				7.8				11.8								
B	1.1	1.5	1.9	2.3				2.5				3.1								
C	3.9	5.9	7.8	11.1	7.8	11.8	15.7	19.6	7.87	11.8	15.7	19.6	23.6	7.87	11.8	15.7	19.6	19.6	27.5	31.4
D	10.6	13.5	16.5	20.7	17.9	21.8	25.7	29.7	19.4	23.4	27.3	31.2	35.2	21	25	28.9	32.8	36.8	40.7	44.6
E	12.5	16.1	19.6	23.6	20.8	24.8	28.7	32.6	22.8	26.7	30.7	34.6	38.5	20.8	24.8	28.7	36.6	40.5	44.4	48.4
F	1.3	1.5	1.9	2.2				2.7				3								
G	2.9	3.7	4.9	5.7				6.6				7.6								
H	3	3	3.5	3.8				4.4				4.7								
L	0.6	0.6	0.6	0.6				0.6				0.6								
lb	14.9	28.4	56.1	63.8	81.4	92.5	103.5	114.5	140.9	151.9	162.9	174	185	209.2	231.2	253.3	275.3	297.3	319.3	341.4