



NAVALHAS E SUPORTES DE SANGRAR

THE NEW VALUE FRONTIER



Small Dia. Cut-off ~ø45

Small Shank General Cut-Off ~ø120

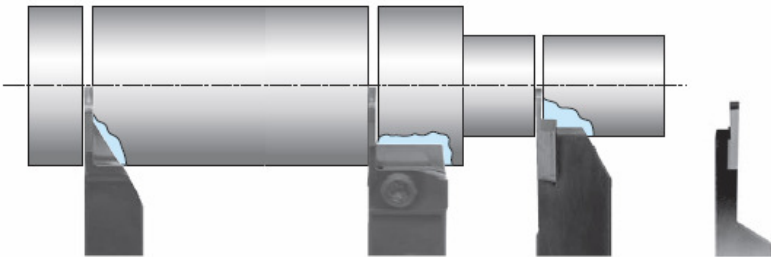

KTKH
Cutting Dia: ~ø45
Shank: □10~25
Edge Width: 2.2~4.1
Self Clamp

KGM
Cutting Dia: ~ø32
Shank: □10~16
Edge Width: 1.5~4.0
Top Clamp

KTKF
Cutting Dia: ~ø16
Shank: □10~16×20
Edge Width: 0.5~2.0
Lateral Side Clamp

KTKFS
Cutting Dia: ~ø16
Shank: □10~12
Edge Width: 1.0~2.0
Lateral Side Clamp

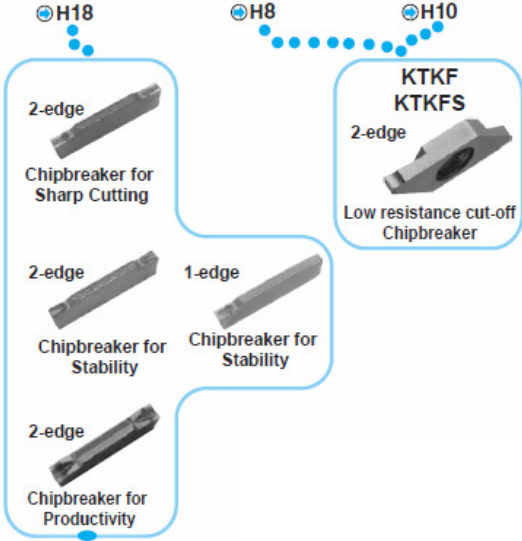
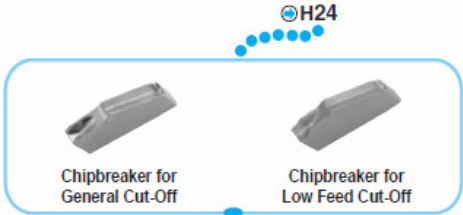

Chipbreaker edge shape	CERACUT Cut-Off H21		
	General Cut-Off		Low Feed Cut-Off
	Chamfer + hone	Sharp Edge	Hone

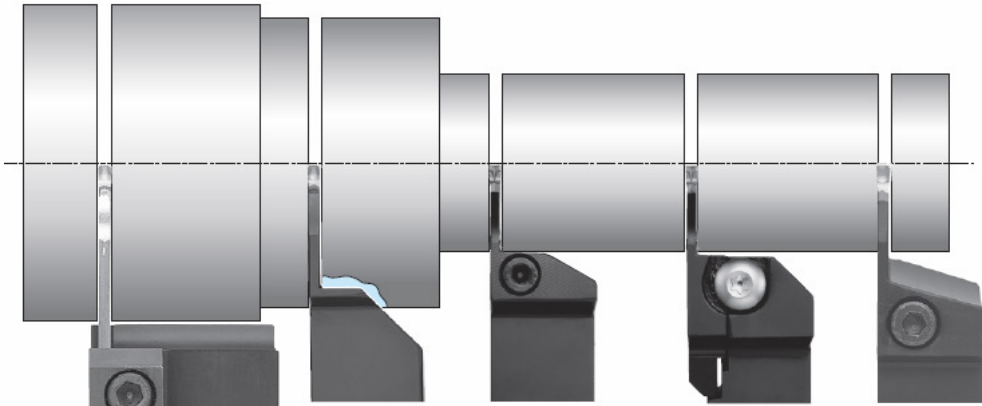

Integral Shank
KGD
Cutting Dia: ~ø50
Shank: □16~32
Edge Width: 2.0~4.0
Top Clamp

Separate Type
KGD-S
Cutting Dia: ~ø50
Shank: □20~32
Edge Width: 2.0~4.0
Top Clamp

Integral Shank
KGM-T
Cutting Dia: ~ø60
Shank: □16~32
Edge Width: 2.0~6.0
Top Clamp

Blade + Toolblock
KTKB
Cutting Dia: ~ø120
Shank: □16~32
Edge Width: 1.6~9.6
Self Clamp

Integral Shank
KTKH
Cutting Dia: ~ø79
Shank: □20~25
Edge Width: 3.1~5.1
Self Clamp

